

COLLECTION
2019



Welcome into our collection 2019.

COLLECTION 2019

“

**HAVE NO FEAR
OF PERFECTION—
YOU’LL NEVER
REACH IT.**

”

Salvador Dali

Why? Because at pulpo, we adore timeless materials and their imperfections, and we believe that every bubble in a handblown glass or every streak in a handmade ceramic glaze is what makes our products unique.

CONTENT CONTENT CONTENT CONTENT CONTE

CONTENT CONTENT CONTENT **CONTENT** CONTENT

6	ABOUT PULPO
8	ABOUT OUR PRODUCTION
10	ABOUT OUR MATERIALS
12	ABOUT OUR DESIGNERS
16	LIGHTING
30	FURNITURE
64	ACCESSORIES
108	LET'S KEEP IN TOUCH
110	CONTACT
112	INFORMATION

OUT PULPO ABOUT PULPO ABOUT PULPO ABOUT



Founded in 2006 by Patrick and Ursula L'hoste, German design brand pulpo produces timeless, unique and highly functional products.

Working in close collaboration with designers and manufactories throughout Europe, pulpo is proud to support young and emerging talent with the bravery to experiment.

Expressing a love of colour and materials through simple yet intriguing forms, the pulpo range has grown from a small collection of accessories to a collection of furniture, lighting and accessories for the home.



Mold of Oda

DUCTION **ABOUT OUR PRODUCTION** ABC

From handblown glass in Northern Italy to handmade ceramic in Germany, we work with local manufacturers to bring you the best quality while seeking to have the least possible impact on our planet.



Ceramic scraps

R MATERIALS **ABOUT OUR MATERIALS** ABC

Glass. Ceramic. Stone.

Noble materials. Natural materials. Striking materials.

But most importantly timeless materials.

Because we want our products to last you a lifetime and more.

DESIGNERS ABOUT OUR DESIGNERS ABOUT OUR

...

Ferréol Babin

e27 Berlin

Studio BrichetZiegler

Studio Furthermore

Meike Harde

Sebastian Herkner

Kai Linke

Davide Monopoli

Peter Raacke

RSW

Michael Schmidt

Elisa Strozyk

Silo Studio

Harry Thaler

Visser & Meijwaard

Sacha Walckhoff

Hermann August Weizenegger

Lorenzo Zanovello

...

**THANK
YOU**

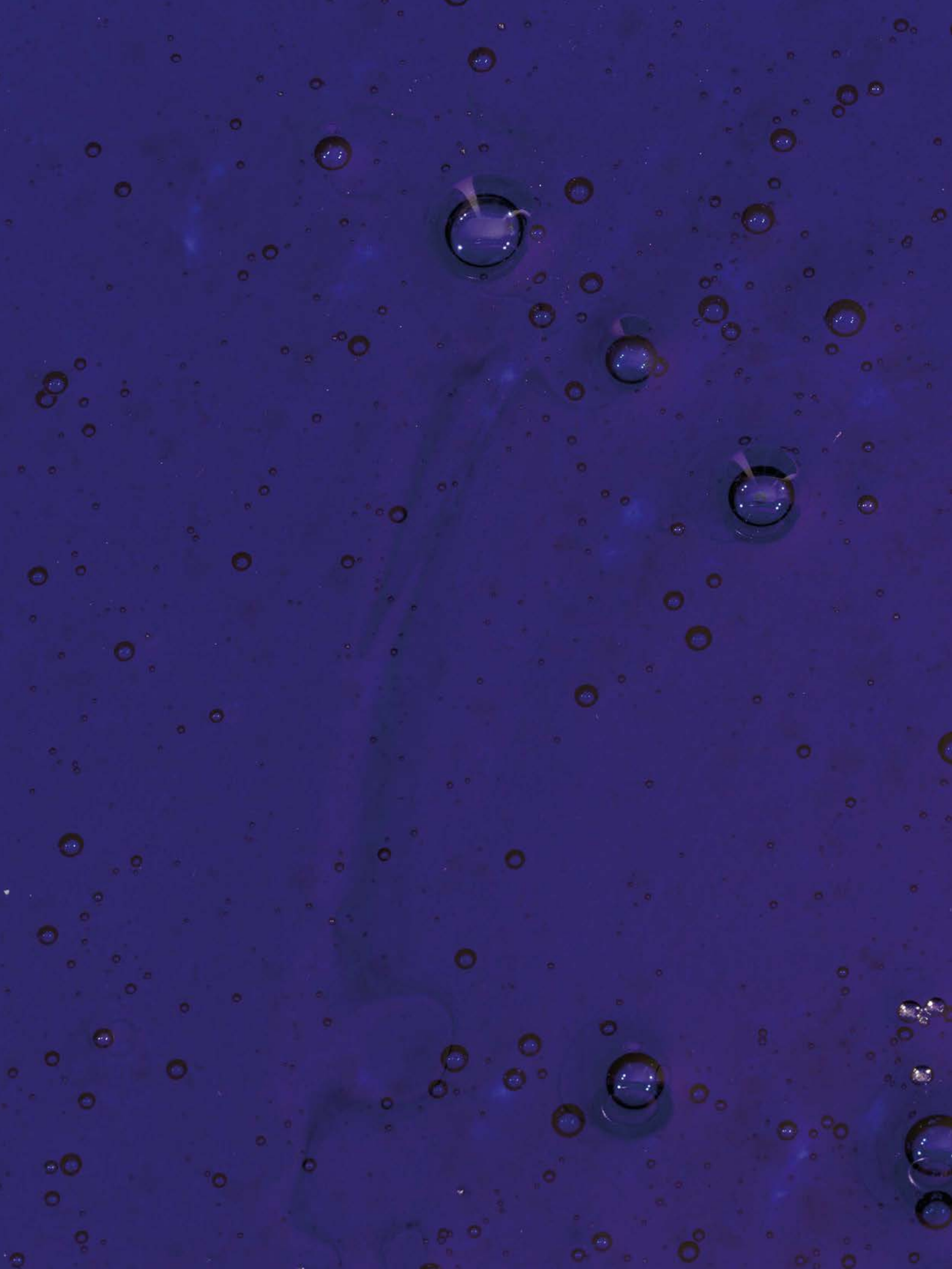

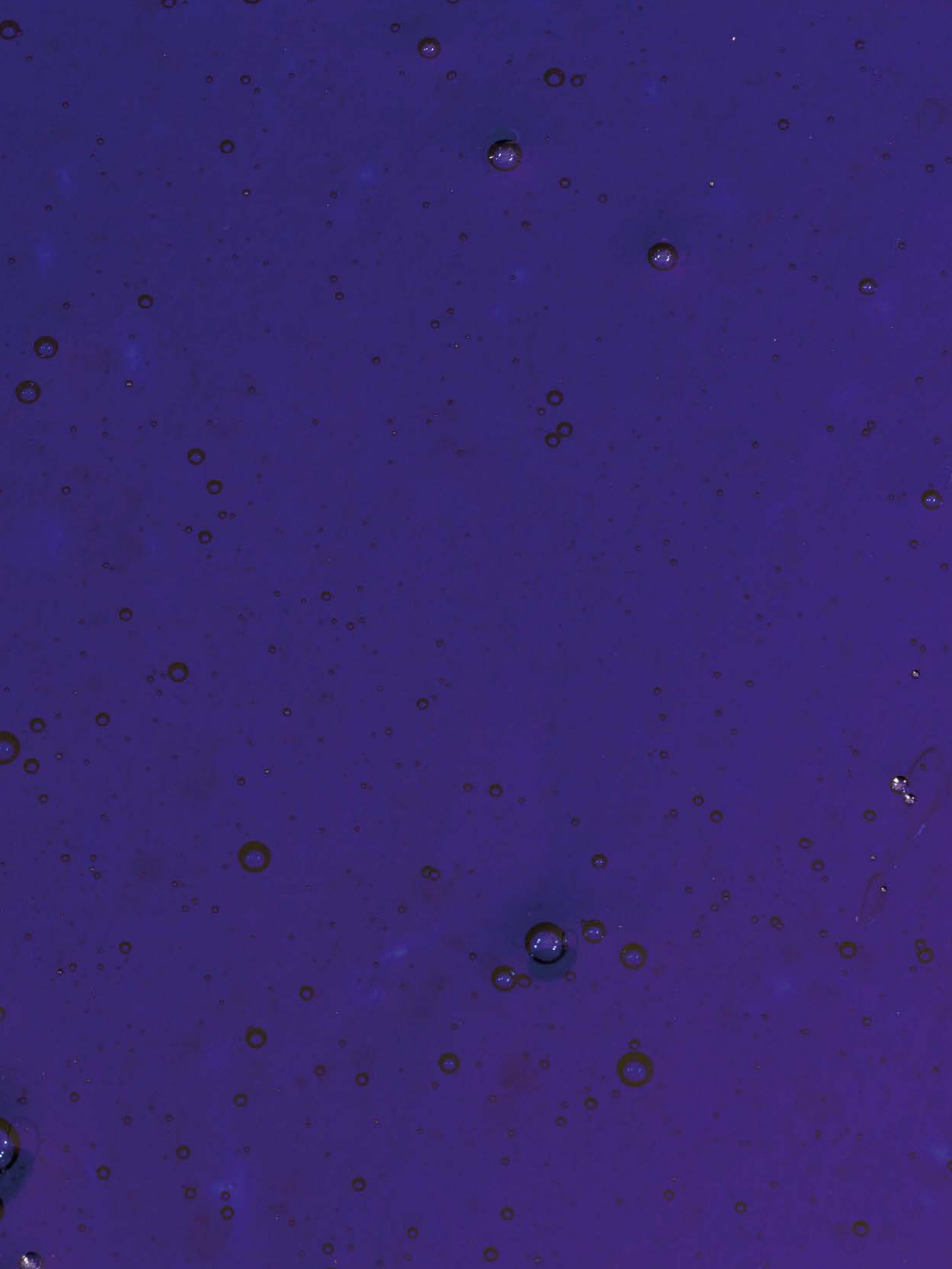

LIGHTING LIGHTING LIGHTING LIGHTING

LIGHTING LIGHTING LIGHTING LIGHTING

LIGHTING LIGHTING LIGHTING LIGHT

**bent
boule
kumo
magma
oda
rl
simple light
steel drop
stellar**

LIGHTING LIGHTING LIGHTING LIGHTING

boule

by Sebastian Herkner

Floating above its ceramic base, the layered glass shades of the Boule lights capture a game of Pétanque in full flight. An illuminated gravity that pulls its audience into a spectacle reminiscent of Provence's favourite pastime: complete with an elongated glow that mirrors the region's famous sun swept evenings.





oda

by Sebastian Herkner

Originally inspired by the photography of Bernd and Hilla Becher, Sebastian Herkner has transported their curved geometric structures into objects filled with warmth and texture. As if bringing the Becher's still images off the page and into life, the Oda lights utilise deep tones and atmospheric transparencies to create a glowing centrepiece in any space.

rl

by Sebastian Herkner



simple light

by Harry Thaler

Illuminating the beauty of natural materials, the Simple Light plays with balance and strength to create an object full of character. Produced from two cylindrical sections of limestone, light escapes through an open end and a cut away underside to allow use as both a task light and an ambient illuminator.



steel drop

by e27 Berlin

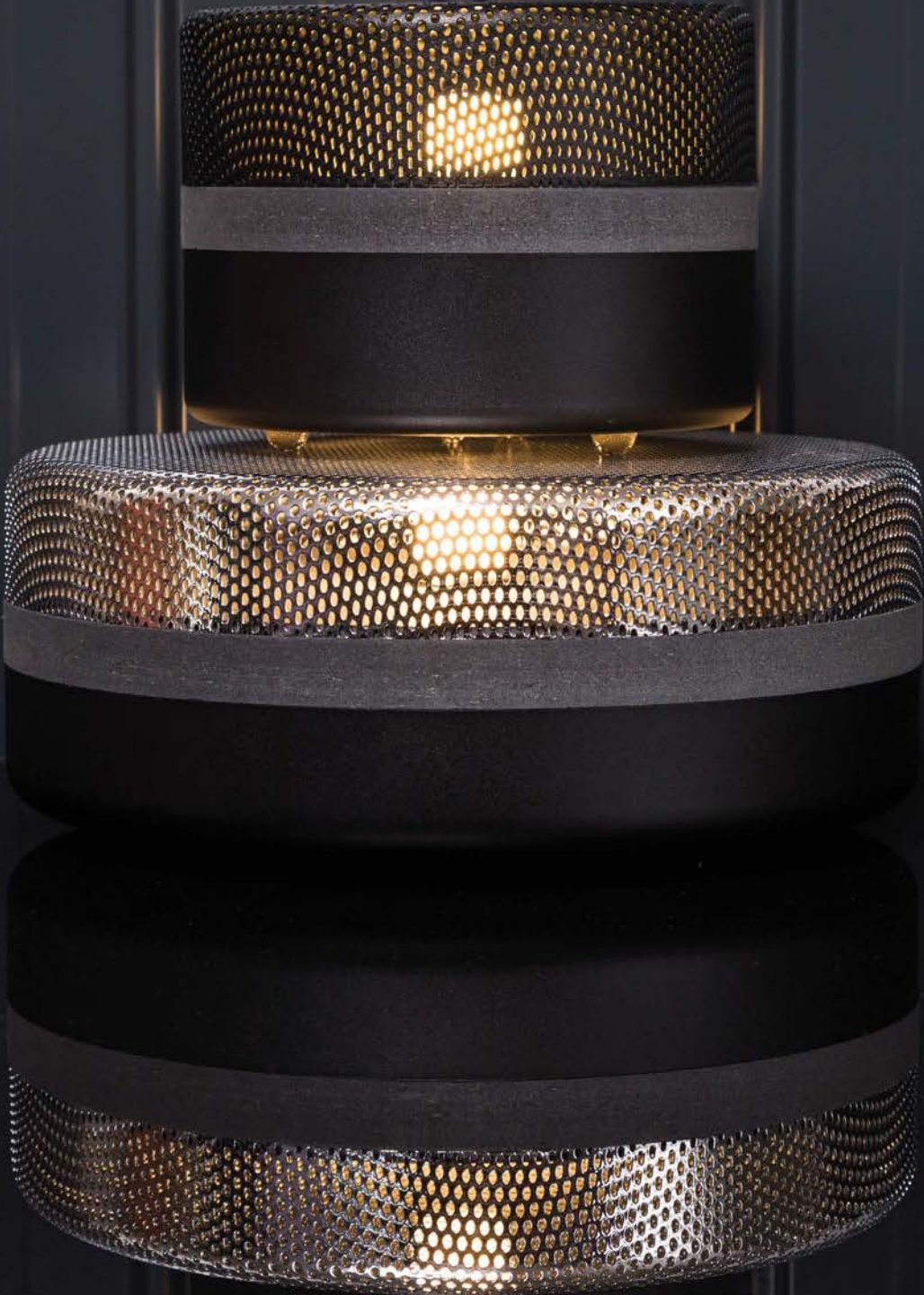



stellar

by Sebastian Herkner

Inspired by the intergalactic, Sebastian Herkner has used repetition in pattern and geometric sensibility to create a collection bordering on the unidentified. Like seeing the night skies brightest through a telescope, Stellar's soft glow requires closer inspection to see its detailed surface. Appearing like deep ravines on the moons surface, its handblown glass form reveals a semi-sphere full of curved ridges. Frosted acetate is added to its smooth opposite, creating a warming glow.

boule

by Sebastian Herkner
TABLE AND FLOOR LAMPS



ART. NR			COLOUR	
SMALL	MEDIUM	HIGH	SHADE	BASE
4600TWS	4700TWS	5000TWS	transparent opal white	black
4600TWW	4700TWW	5000TWW	transparent opal white	white
4600TGS	4700TGS	5000TGS	transparent smoky grey	black
4600TGW	4700TGW	5000TGW	transparent smoky grey	white
4600GWS	4700GWS	5000GWS	smoky grey opal white	black
4600GWW	4700GWW	5000GWW	smoky grey opal white	white
4600GGS	4700GGS	5000GGS	smoky grey smoky grey	black
4600GGC	4700GGC	5000GGC	smoky grey smoky grey	colombia
4600GGW	4700GGW	5000GGW	smoky grey smoky grey	white

MATERIAL

glass and ceramic

LIGHT SOURCE

SMALL

BULB LED, E27, 7W, 80Ø × 120H mm, 806lm, 2700K warm white, 220-240V, 50/60Hz, 30'000h, A++
CABLE 4000mm, with foot switch and Euro plug

MEDIUM

BULB LED, E27, 7W, 125Ø × 170H mm, 806lm, 2700K warm white, 220-240V, 50/60Hz, 30'000h, A++
CABLE 4000mm, with foot switch and Euro plug

BIG

BULB LED, E27, 7W, 80Ø × 120H mm, 806lm, 2700K warm white, 220-240V, 50/60Hz, 30'000h, A++
CABLE 4000mm, with foot switch and Euro plug

PROCESS

Each piece is created from uncoloured or coloured handblown glass. The base is handmade in ceramic, then applied with a satin glaze. Bubbles, streaks, and other variations in size and colour are part of the handmade production process, and not defects of the design or production.

DIMENSIONS mm

SMALL

290Ø × 355H
OUTER SHADE 290Ø
INNER SHADE 160Ø

MEDIUM

580Ø × 740H
OUTER SHADE 580Ø
INNER SHADE 320Ø

HIGH

520Ø × 825H
OUTER SHADE 520Ø
INNER SHADE 250Ø

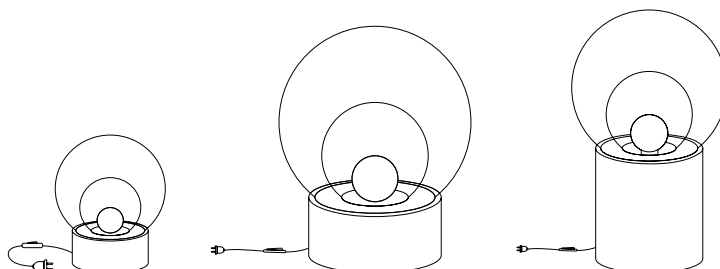

oda

by Sebastian Herkner
TABLE AND FLOOR LAMPS



ART. NR			COLOUR	
SMALL	MEDIUM	BIG	SHADE	BASE
3060AS	3030AS	3050AS	amber	black
3060AMACS	-	-	amber acetato	black
3060AUBS	3030AUBS	3050AUBS	aubergine	black
3060AUBBR	3030AUBBR	3050AUBBR	aubergine	brass
3060AUBCHR	3030AUBCHR	3050AUBCHR	aubergine	chrome
3060MLS	3030MLS	3050MLS	moonlight white	black
3060MLW	3030MLW	3050MLW	moonlight white	white
3060GS	3030GS	3050GS	smoky grey	black
3060GBR	3030GBR	3050GBR	smoky grey	brass
3060GCHR	3030GCHR	3050GCHR	smoky grey	chrome
3060GACS	3030GACS	3050GACS	smoky grey acetato	black
3060GACBR	3030GACBR	3050GACBR	smoky grey acetato	brass
3060GACCHR	3030GACCHR	3050GACCHR	smoky grey acetato	chrome
3060VWS	3030VWS	3050VWS	white	black
3060VWW	3030VWW	3050VWW	white	white

MATERIAL

glass and steel

LIGHT SOURCE

SMALL

BULB LED filament, E14, 1W, 39Ø x 103H mm, 105lm, 2500K warm white, 220-240V, 50/60Hz, 30'000h, A++

CABLE 3000mm, with hand switch and Euro plug

MEDIUM AND BIG

BULB LED filament, E27, 2W, 64Ø x 142H mm, 250lm, 2100K warm white, 220-240V, 50/60Hz, 30'000h, A++

CABLE 4000mm with foot switch and Euro plug

PROCESS

Each piece is created from coloured handblown glass. The frame is constructed in either steel; powder coated or chrome plated, or brass. Bubbles, streaks and other variations in size and colour are part of the production process, and not defects of the design or production.

DIMENSIONS mm

SMALL

240Ø x 450H

MEDIUM

450Ø x 850H

BIG

450Ø x 1400H

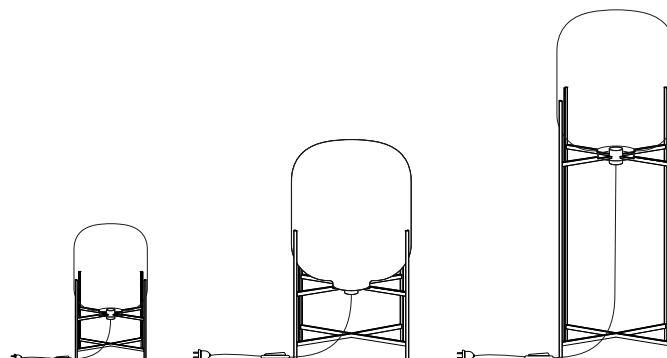

rl

by Sebastian Herkner
PENDANT AND FLOOR LAMPS



ART. NR

1 **2**
9000B **9001B**

COLOUR

aluminium | black

MATERIAL

aluminium and steel

LIGHT SOURCE

1

BULB LED tube, 12W, 750lm/m, 60LEDs/m, INPUT 24V, 0.625A max., 50/60Hz

CABLE 4000mm, with foot dimmer; with Euro, UK and AUS plugs, and with AC adaptor; INPUT 100-240V, 0.5A max, 50/60Hz, OUTPUT 24V, 0.625A

2

BULB LED tube, 12W, 750lm/m, 60LEDs/m, INPUT 24V, 0.625A max., 50/60Hz

CABLE 4000mm, with foot dimmer; with Euro, UK and AUS plugs, and with AC adaptor; INPUT 100-240V, 0.5A max, 50/60Hz, OUTPUT 24V, 0.625A

PROCESS

Each piece is created from a textured aluminium shade and a base constructed in powder coated steel.

DIMENSIONS mm

1

120Ø × 1220H

2

300Ø × 1600H

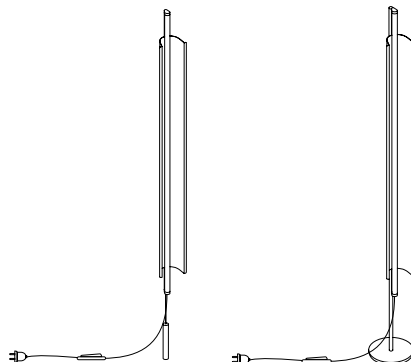

simple light

by Harry Thaler
TABLE LAMP



ART. NR

COLOUR

3100B

limestone | brass

MATERIAL

limestone and brass

LIGHT SOURCE

BULB LED, E14, 5W, 45Ø x 76H mm, 420lm, 2700K warm white, 230V, 50/60Hz, 15'000h, A+
CABLE 3000mm, with hand switch and Euro plug

PROCESS

Each piece is created from two limestone cylinders; and finished with a brushed brass disk.

DIMENSIONS mm

256L x 90W x 250H

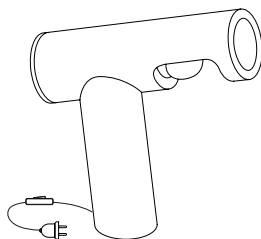

steel drop

by e27 Berlin
TABLE LAMPS

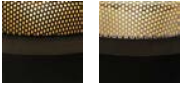
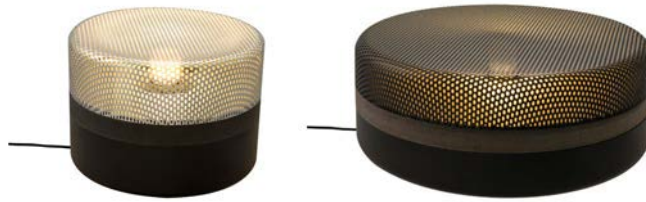

ART. NR

SMALL	BIG
2600S	2700S
2600SCHR	2700SCHR

COLOUR

SHADE	BASE
black	black
chrome	black

MATERIAL

steel and wood

LIGHT SOURCE

SMALL AND LARGE

BULB LED, E27, 3W, 32Ø × 59H mm, 230lm, 2700K warm white, 230V, 50/60Hz, 15'000h, A+

CABLE 3000mm, with hand switch and Euro plug

PROCESS

Each piece is created from unperforated and perforated steel; powder coated, or chrome plated (1,5mm); separated by a black MDF disk.

DIMENSIONS mm

SMALL

200Ø × 150H

MEDIUM

320Ø × 130H

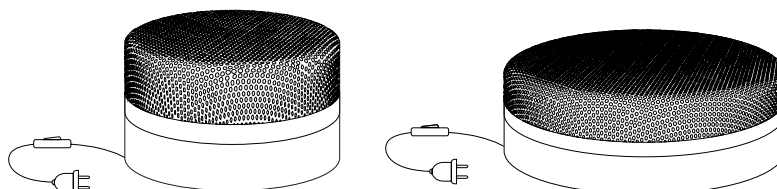

stellar

by Sebastian Herkner
PENDANT LAMPS

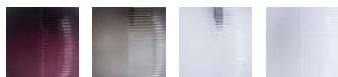

ART. NR				COLOUR	
MINI	SMALL	MEDIUM	BIG	HALF	HALF
7903AUB_50	7900AUB_50	7901AUB_50	7902AUB_50	aubergine acetato	aubergine
7903G_50	7900G_50	7901G_50	7902G_50	smoky grey acetato	smoky grey
7903T_50	7900T_50	7901T_50	7902T_50	transparent acetato	transparent
7903W_50	7900W_50	7901W_50	7902W_50	white acetato	white

MATERIAL

glass and steel

LIGHT SOURCE

MINI AND SMALL

BULB LED, E27, 4W, 45Ø x 75H mm, 400lm, 2700K warm white, 220-240V, 50/60Hz, 30'000h, A++

CABLE 3200mm textile cable, 3900mm stainless steel wire and ceiling cup

MEDIUM AND BIG

BULB LED filament, E27, 2W, 364Ø x 142H mm, 250lm, 2100K warm white, 220-240V, 50/60Hz, 30'000h, A++

CABLE 4000mm, with foot switch and Euro plug

PROCESS

Each piece is created from uncoloured or coloured, partly-sand-blasted, handblown glass. Bubbles, streaks and other variations in size and colour are part of the production process, and not defects of the design or production.

DIMENSIONS mm

MIN

180Ø

SMALL

230Ø

MEDIUM

310Ø

BIG

390Ø

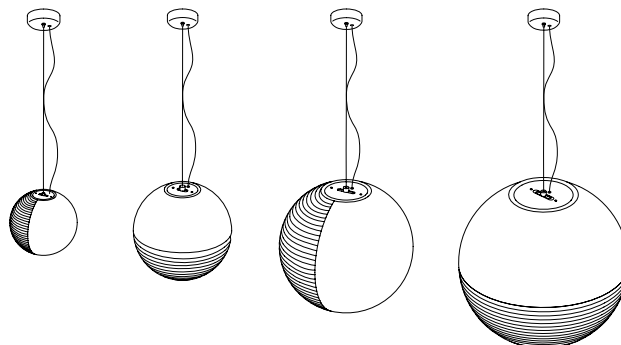

TURE FURNITURE FURNITURE FURN

ITURE FURNITURE FURNITURE FURN

FURNITURE FURNITURE FURNITURE FURNITURE FURNITURE

alwa

blash

chiara&fosco

chouchou

container table

cut

delight

font

gin

kaboom+oooh+pow

madison

mila

miro

pallet

passerelle

FURNITURE FURNITURE FURNITURE FURNITURE FURNITURE

alwa

by Sebastian Herkner

Championing imperfection. Celebrating the beauty of each unique ripple, bubble and swirl. The Alwa collection of coffee and side tables traps the movement of glass in a generous time capsule. Inspired by undulating surface water, the collection mixes a sturdy form with a soft aesthetic.



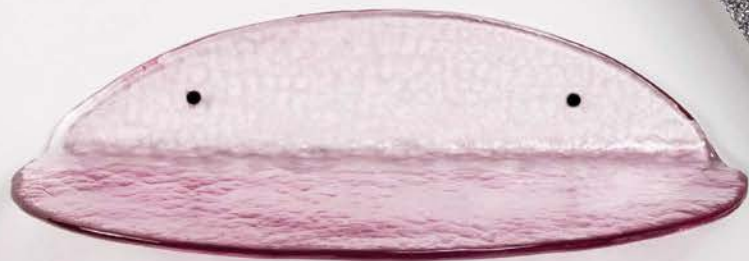

blash

by Silo Studio

A round piece of glass bent into place and affixed to your wall. The Blash wall shelves have all the necessary elements to display your treasured possessions: and nothing more. While simple in nature, their cast glass construction retains ripples and textures into their final form.



chiara&fosco

by Elisa Strozyk

Sitting atop a simple black steel frame, the Chiara&Fosco side table series firmly highlights its circular centrepiece. Mixing a ceramic structure with a series of black or white ceramic pigments, fluctuating forms are produced by spinning the circular top whilst blowing on its surface - before the pigments have set. The result is billowing clouds of intertwined pigments streaming across its circular form.



chouchou

by Lorenzo Zanovello

Like the joy of stumbling across a Chouchou cart in France; the distinct form is a substitute for the caramelized smell of its peanut candy namesake. Just too hard to resist, its ceramic form adds a tactile feel to the Chouchou stool. Available in a black, deep blue or bright pink gloss glaze, its shape speaks to the history of ceramic design in a contemporary form. A truly unique addition to any interior. Who wouldn't want a chance encounter with Chouchou a little more often?



container table

by Sebastian Herkner

cut

by Studio BrichetZiegler

A simple metal base is covered in a single sheet of leather. Rather than pulling this leather layer taut, the leather between the chair seat and back is allowed to react in its own way, creating a point of visual interest. The simple affixing of leather to metal again appears in the ottoman design tying the series together.



delight

by Sebastian Herkner

Much like their namesake, the Delight side tables exude a soft glow through their translucent structures. Produced from handblown glass, their unique form is reminiscent of a pair of candy cubes sweetly fused into one. Inviting curves highlighted by a textured and frosted or glossy exterior that keeps you coming back for one more bite.





font

by Sebastian Herkner

A series of graphic forms that play with perceptions of geometry and perspective. From low and high square units that contain space below for your favourite read, to the sculptural Font Round side tables that express the true beauty of the material. A colour range from jade and green, ocean blue and polar white, to champagne brown, further highlights the Font series' connection to core elements and the exploration of new materials.



gin

by Sebastian Herkner

One part coloured, two parts lacquered. Or was it three parts mirrored to one part textured gold. Inspired by the endless possibilities of glass; composition, texture and finishing, the Gin series of tables are as balanced as your favourite evening beverage. Sebastian Herkner has acted as mixologist on a set of tables – simple in appearance, that dive head first into the endless world of glass. Celebrating a centuries old material with a contemporary twist of lime.

Kaboom + Oooh + Pow

by Hermann August Weizenegger

Putting the exclamation point on your interior paragraph is a series that is as bold as it is cosy. Kaboom + Oooh + Pow is just that! Inspired by the scale and shapes of Bauhaus architecture - yet softened by a fully upholstered form, the series provides strong lines and soft surfaces.



madison

by Michael Schmidt

The Madison bar wagon blends strong lines and luxurious materials to bring a sense of class to your next social gathering. An option of black lacquered oak or oiled natural walnut is topped with a stainless steel frame and finished with a touch of coloured glass to create a balance of form and function.





mila

by Sebastian Herkner

Sensuous curves meet striking lines - an exercise in shape and composition. Testing the boundaries of material and form, Sebastian Herkner has utilised the strengths and tested the limits of ceramic production. The Mila tables' bold physique demonstrates a balanced playfulness; playfulness highlighted through a bold set of colours fit for any setting.

miro

by Meike Harde





pallet

by Sebastian Herkner



passerelle

by Sebastian Herkner

With the ability to be stacked high; or spread out over your interior, the simple steel frame and frosted profilit glass planes accentuate the sophisticated outline of the Passerelle shelving system. Inspired by the Venetian footbridges that keep residents safe in times of flooding, it provides a safe place for all of your most beloved possessions.

alwa

by Sebastian Herkner
TABLES

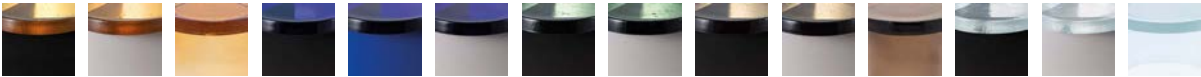

ART. NR						COLOUR		
ONE	ONE BIG	TWO	TWO BIG	THREE	THREE BIG	TOP	BASE - STEEL	BASE - GLASS
5500Y-D	5501Y-D	5600Y-D	5601Y-D	5800Y	5801Y	amber	black	amber
5500Y-SI	5501Y-SI	5600Y-SI	5601Y-SI	-	-	amber	silver	-
5500B-D	5501B-D	5600B-D	5601B-D	-	-	blue	black	-
5500B-B	-	5600B-B	-	-	-	blue	blue	-
5500B-SI	5501B-SI	5600B-SI	5601B-SI	-	-	blue	silver	-
5500GRE-D	5501GRE-D	5600GRE-D	5601GRE-D	-	-	green	black	-
5500GRE-SI	5501GRE-SI	5600GRE-SI	5601GRE-SI	-	-	green	silver	-
5500G-D	5501G-D	5600G-D	5601G-D	5800G	5801G	smoky grey	black	smoky grey
5500G-SI	5501G-SI	5600G-SI	5601G-SI	-	-	smoky grey	silver	-
5500T-D	5501T-D	5600T-D	5601T-D	5800T	5801T	transparent	black	transparent
5500T-SI	5501T-SI	5600T-SI	5601T-SI	-	-	transparent	silver	-

MATERIAL

glass and steel

PROCESS

Each piece is created from uncoloured or coloured cast glass. The base is constructed in steel; powder coated or coloured handblown glass. Bubbles, streaks and other variations in size and colour are part of the production process, and not defects of the design or production.

DIMENSIONS mm

ONE, TWO AND THREE

380Ø x 440H

ONE BIG, TWO BIG AND THREE BIG

560Ø x 350H

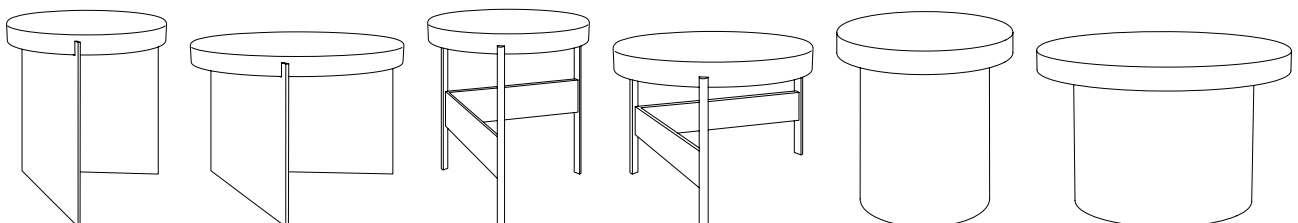

blash

by Silo Studio
SHELVES

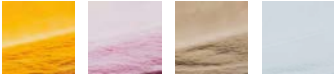

ART. NR

SMALL

MEDIUM

I400A

I401A

I400PI

I401PI

I400G

I401G

I400T

I401T

COLOUR

amber

pink

grey

transparent

MATERIAL

glass

PROCESS

Each piece is created from uncoloured or coloured cast glass. Bubbles, streaks and other variations in size and colour are part of the production process, and not defects of the design or production.

DIMENSIONS mm

SMALL

300L x 200W x 110H

MEDIUM

500L x 200W x 110H

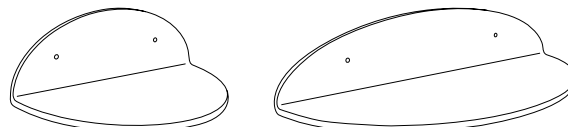

chiara&fosco

by Elisa Strozyk
TABLES



ART. NR

SMALL	LARGE	HIGH
4800S	4801S	4802S
4900VV	4901VV	4902VV

COLOUR

TOP	BASE
black smoke-like pattern	black
white smoke-like pattern	black

MATERIAL

cordieriet and steel

PROCESS

Each piece is created from cordieriet, ceramic glazed. Each piece and pattern are unique. The frame is constructed in black powder coated steel. Bubbles, streaks and other variations in size and colour are part of the handmade production process, and not defects of the design or production.

DIMENSIONS mm

SMALL
380Ø × 410H
LARGE
520Ø × 490H
HIGH
470Ø × 620H



chouchou

by Lorenzo Zanovello
STOOL



ART. NR

COLOUR

I700B

black

I700BL

blue

I700PI

pink

MATERIAL

ceramic

PROCESS

Each piece is handmade in Italy, created from gloss glazed ceramic. Streaks and other variations in size and colour are part of the production process, and not defects of the design or production.

DIMENSIONS mm

350L x 300W x 430H

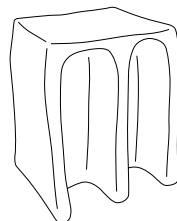

container table

by Sebastian Herkner
TABLE



ART. NR

COLOUR

	TABLE	TRAY
3090O-S	orange	black
3090O	orange	blue
3090RO	rose	blue
3090BL	light blue	red
3090SI	silver	white

MATERIAL

glass

PROCESS

Each piece is created from handblown glass, coloured and/or silvered. Bubbles, streaks and other variations in size and colour are part of handmade production processes, and not defects in the design or production.

DIMENSIONS mm

390Ø x 400H

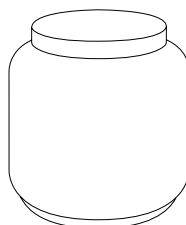

CUT

by Studio BrichetZiegler
CHAIR AND OTTOMAN



ART. NR

CHAIR

OTTOMAN

I500B

I501B

I500GR

I501GR

COLOUR

LEATHER

FRAME

black

black

green

green

MATERIAL

leather and steel

PROCESS

Handmade in France, the legs and frame are constructed from powder coated steel. A single piece of tanned leather is then glued to the metal frame. Marks and folds in the leather are part of the production process, and not defects of the design or production.

DIMENSIONS mm

CHAIR

600L x 565W x 735H

SEAT 390H

OTTOMAN

600L x 470W x 450H

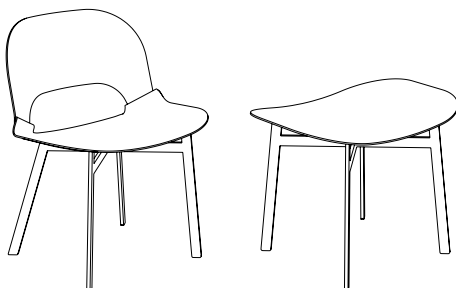

delight

by Sebastian Herkner
TABLES



ART. NR		COLOUR
SMALL	BIG	
9300AUB	9301AUB	aubergine
9300AUBAC	9301AUBAC	aubergine acetato
9300G	9301G	smoky grey
9300GAC	9301GAC	smoky grey acetato
9300T	9301T	tarpaulin
9300TAC	9301TAC	tarpaulin acetato

MATERIAL

glass

PROCESS

Each piece is created from handblown glass, coloured and/or sanded. Bubbles, streaks and other variations in size and colour are part of handmade production processes, and not defects in the design or production.

DIMENSIONS mm

SMALL

360Ø × 380H

BIG

460Ø × 500H

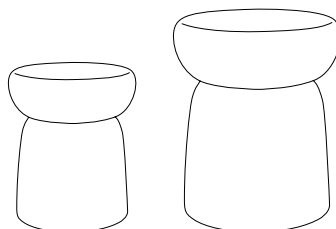

font

by Sebastian Herkner
TABLES



ART. NR					COLOUR
LOW	HIGH	ROUND SMALL	ROUND LARGE	ROUND HIGH	
3400BR	3500BR	3600BR	3601BR	3602BR	champagne brown
3400GR	3500GR	3600GR	3601GR	3602GR	green
3400J	3500J	3600J	3601J	3602J	jade
3400BL	3500BL	3600BL	3601BL	3602BL	ocean blue
3400VV	3500VV	3600VV	3601VV	3602VV	polar white

MATERIAL

glass ceramic

PROCESS

Each piece is created from glass ceramic. Bubbles, streaks and other variations in size and colour are part of handmade production processes, and not defects in the design or production.

DIMENSIONS mm

LOW

420L x 420W x 360H

HIGH

340L x 340W x 480H

ROUND SMALL

440Ø x 360H

ROUND LARGE

500Ø x 420H

ROUND HIGH

360Ø x 540H

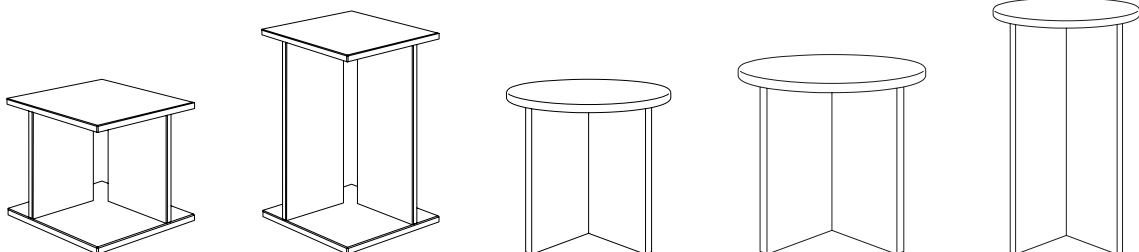

gin

by Sebastian Herkner
TABLES

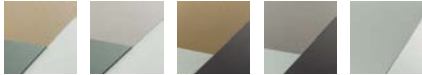

ART. NR

MEDIUM	LARGE	HIGH
2901GO	2902GO	2900
2901SI	2902SI	-

COLOUR

TOP - MEDIUM	TOP - LARGE	TOP - HIGH	BASE
dark green gold white	black gold white	white mirror	black
dark green silver white	black silver white	-	black

MATERIAL

glass and steel

PROCESS

Each piece is created from glass sheet in a combination of coloured, lacquered, textured and mirrored finishes. The frame is constructed in black powder coated steel.

DIMENSIONS mm

MEDIUM
750Ø x 400H

LARGE
1000Ø x 310H

HIGH
500Ø x 500H

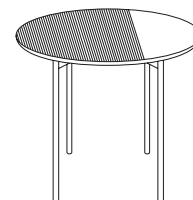
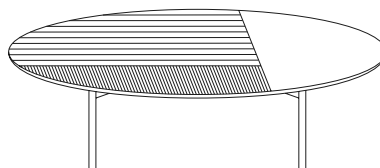
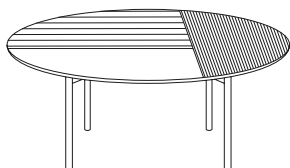

kaboom+oooh+pow

by Hermann August Weizenegger
 ARMCHAIRS, OTTOMAN AND SOFA

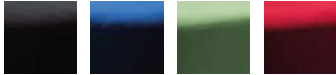

ART. NR				COLOUR	
KABOOM	OOOH	POW ARMCHAIR	POW SOFA	VELVET	FEET
9202S	9204S	9200S	9203S	black	black
9202BL	9204BL	9200BL	9203BL	blue	black
9202GRE	9204GRE	9200GRE	9203GRE	green	black
9202R	9204R	9200R	9203R	red	black

MATERIAL

fabric, foam and steel

PROCESS

Each piece is created from foam-based sit, covered in velvet. The feet are constructed in powdered coated steel.

DIMENSIONS mm

KABOOM

1050L x 900W x 1360H

SEAT 420H

OOOH

460Ø x 420H

POW ARMCHAIR

1050L x 900W x 600H

SEAT 420H

POW SOFA

1650L x 900W x 600H

SEAT 420H

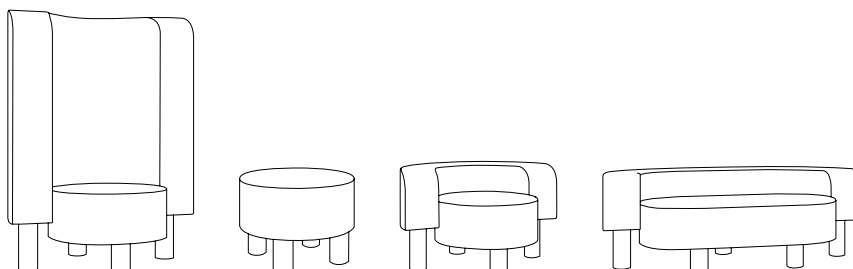

madison

by Michael Schmidt
BAR TROLLEY



ART. NR

9400BL
9400NA

COLOUR

MAIN ELEMENT

black oak
nature ash

SHELF | CUBE | SHEET

smoky grey | steel | smoky grey
smoky grey | steel | smoky grey

MATERIAL

wood, steel and glass

PROCESS

Each piece is created from black stained oak or natural ash. The frame and cube are constructed in stainless polished steel. The shelf and top sheet are made from coloured glass.

DIMENSIONS mm

1220L x 480W x 800H

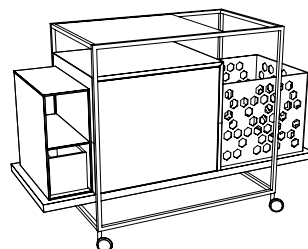

mila

by Sebastian Herkner
TABLES



ART. NR			COLOUR
SMALL	LARGE	HIGH	
2800S	2801S	2802S	black
2800BL	2801BL	2802BL	blue
2800GR	2801GR	2802GR	grey
2800RO	2801RO	2802RO	rose
2800W	2801W	2802W	white
2800Y	2801Y	2802Y	yellow

MATERIAL

ceramic

PROCESS

Each piece is created from gloss glazed ceramic. Streaks and other variations in size and colour are part of the handmade production process, and not defects of the design or production.

DIMENSIONS mm

SMALL
460Ø × 430H

LARGE
540Ø × 360H

HIGH
360Ø × 480H

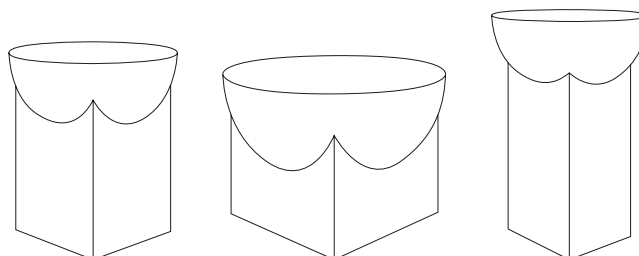

miro

by Meike Harde
WARDROBE / MIRROR

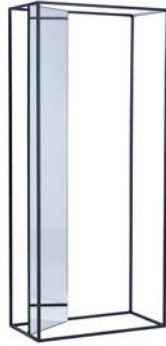

ART. NR

6500AN
6500SI

COLOUR

MIRROR	FRAME
antique	black
silver	black

MATERIAL

glass and steel

PROCESS

Each piece is created from glass sheet in an antique effect or a natural finishing, mounted on a black MDF. The frame is constructed in black powder coated steel.

DIMENSIONS mm

FRAME

2000L x 800W x 1800H

MIRROR

2000L x 10W x 1800H

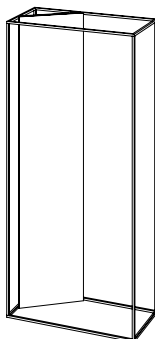

pallet

by Sebastian Herkner
DAY BED



ART. NR

COLOUR

	FABRIC	FRAME
4400LB-SS	black leather	black
4400LB-ON	black leather	nature
4400LT-SS	terracotta leather	black
4400LT-ON	terracotta leather	nature
4400G-SS	dark grey velvet	black
4400G-ON	dark grey velvet	nature
4400PI-SS	dirty pink velvet	black
4400PI-ON	dirty pink velvet	nature

MATERIAL

fabric, foam and wood

PROCESS

Each piece is created from foam-based sit, covered in either leather (by Stolz) or velvet (by Redaelli). The frame is constructed in natural or black-stained oak, weaves with natural or black jute.

DIMENSIONS mm

FRAME

2000L x 800W x 290H

MATTRESS

2000L x 800W x 80H

PILLOW

800L x 100W x 80H

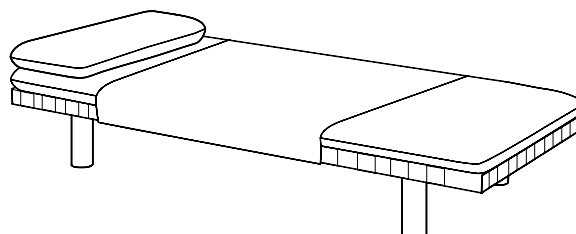

passerelle

by Sebastian Herkner
SHELVES



ART. NR

100

160

COLOUR

SHELF

FRAME

9600S-01

9700S-01

transparent

black

9600S-02

9700S-02

transparent

black

9600S-03

9700S-03

transparent

black

9600S-04

9700S-04

transparent

black

9600S-05

9700S-05

transparent

black

MATERIAL

glass and steel

PROCESS

Each piece is created from transparent proflit glass, cut by hand. The frame is constructed from black powder coated steel. Each unit it stackable, up to five units high.

DIMENSIONS mm

100

1000L x 320W x 390H until 1000L x 320W x 1950H

160

1600L x 320W x 390H until 1600L x 320W x 1950H

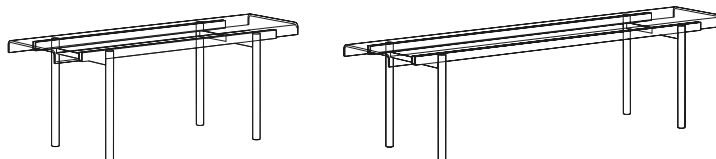

ACCESSORIES ACCESSORIES ACCESSORIES AC

ACCESSORIES ACCESSORIES ACCESSORIES

CESSORIES ACCESSORIES ACCESSORIES

**atoll
black
bola
building
container
deer+giraffe+rhino+swan
dita+olivia
fg
lake
llano
maket
makeup
marelle
merit
mila bowl
miro on the wall
mountain
neolit
potpourri
tray**

SORIES ACCESSORIES ACCESSORIES AC

atoll

by Sebastian Herkner

For the Atoll series Sebastian Herkner has accentuated the solid potential of cast glass through a series of organic forms. These simple forms refer to the free-form nature of volcanic islands - much like the changing of glass from liquid to solid. Punctuated simply with a series of holes in which to place your candles, the Atoll series does not over-complicate, simply bringing the beauty of cast glass to the fore.





black

by pulpo

A first in a occasional look into a colour close to the pulpo families' heart; Black is a celebration of a colour as associated with the beginning to time as it is to our own mortality. We have brought together a selection of our collaborative designers and artists to each convey their own connection to - and interpretations of, black. The result is a book as scientific as it is emotive, filled with words, works and findings from some of the design world's most creative minds.

bola

by RSW

Transporting you to the glamour of 1920's New York, the Bola boxes hark back to the containers of Tiffany. Featuring generous chamfered edges and a depp stained beech wood exterior, their low silhouettes are topped off with a jewel-like ceramic button.





building

by Ferréol Babin

This Building boxes bring to mind the industrial areas so familiar within our urban landscapes. An industrial aesthetic accentuated by the deep black, a merlot red or metal brown glazed finish to their ceramic structures. With a stretched out footprint, its lined exterior is topped with an equally generous cantilevered top. Space enough to keep all your possessions under one roof.



container

by Sebastian Herkner

An alluring mix of reflections and transparencies, brought to life through a colourful-silvered glass construction. With an array of colour combinations available, they can accentuate a bountiful bouquet or become a prized statement piece.

deer + giraffe + rhino + swan

by Kai Linke

Make comrades with a swan that can glide into your open hand; or a slender and proud giraffe. A curious deer amongst your own tablescapes savannah; or maybe it's the elusive rhino to complete your centrepiece. Each of Kai Linke's pieces have been sculpted and formed by hand using paper and tape. A simplicity in construction that has been charmingly honoured through to the final cast bronze forms. Each crease and line has remained intact; creating a charismatic group you will want to touch and hold.



dita + olivia

by Davide Monopoli

A kaleidoscope of colour is combined with a subtle softness in shape, taking the titles of the round and stout Dita, and the tall and thin Olivia. This reflective duo brings a pop of colour into your interior in the form of paired back table mirrors.





fg

by Visser & Meijwaard

With a treasured function of containing your precious items, the FG vases and boxes fuse 18th century function with a 21st century taste for pure fiction. Featuring decoration that is both ancient and futuristic in appearance, its ceramic form is further mystified by the matt black glaze to its exterior.



lake

by Ferréol Babin

These Lake trays make the perfect spot to take a respite; to sit back, relax and enjoy a beverage. Or better still share a drink around their flowing forms, whimsically crafted out of glazed ceramic. With a shimmering finish, you can choose between a mesmerizing emerald, a tropical turquoise getaway, and a cooling cobalt lakeside vista.

Ilano

by RSW

Reminiscent of ancient China, the Ilano set of boxes detail a more eastern appeal. An oxidised green stained covers the geometric beech wood exterior, topped off with the circular form in shimmering black ceramic. Not to be content housing jewels, these boxes exude their own prized qualities, transforming themselves into cherished tablescene items for future generations.





maket

by RSW

Rising up above your tablescape comes the volcanic inspired Maket vase. Its ceramic form is topped with a fat lava glaze full of bubbles and texture; flowing down its stepped form to a base finished in a series of matt glazed colours. Take apart these two sections to create your own two-toned display vessel full of sharp lines and textured finishes.



makeup

by Hermann August Weizenegger

Utilising traditional thrown ceramic production, the Makeup series has been finished in a metallic, iridescent glaze that creates a group full of movement and colour. The warmth of ceramic mixes with these futuristic colours and reflections to create objects full of intrigue – just asking to be touched and held.

marelle

by Sacha Walckhoff

Designed by Sacha Walckhoff - who himself is a mix of the fashion and interior worlds; the designer has taken the humble rug into new territory. With a mix-and-match approach, Marelle's components can simply be taken apart or brought together using zips. Like adding a winter jacket to your favourite outfit, Marelle can grow and shrink at a whim. Adding together sections of cross patterned rugs, muted or vibrant camouflage areas, or large abstract canvases; this series allows you to create your own collage.





merit

by RSW

The Merit collection features the striking use of a fat lava glaze to their upper half, a technique created in Germany during the early 20th century. The bubbles and streaks of the glossy lava glaze cascade down their stepped exterior, halting at the vibrant colours beneath. The smooth lines of pinks, blues and greys below offset the grandiose scene above. This contrast is further highlighted by a soft, matt finished to their coloured ceramic undersides.



mila bowl

by Sebastian Herkner

Melding a rigid square base and curvaceous top form, the Mila Bowl is a bold accessory addition. The coming together of these seemingly separate forms tests the limits of ceramic production techniques – while its high gloss exterior highlights the exact kiss of straight lines and a curved underside.

miro on the wall

by Meike Harde

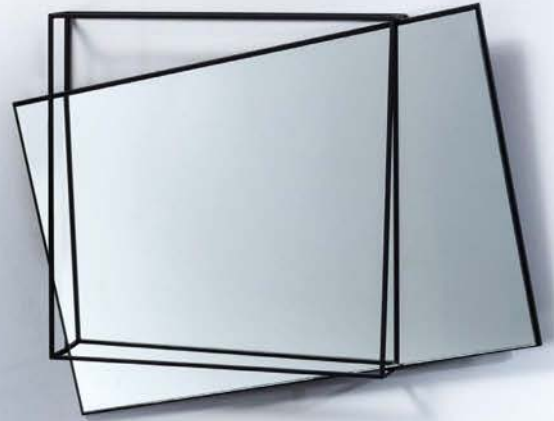



mountain

by Ferréol Babin

Making a dramatic entrance overtop your tablescape below comes the Mountain vases. Its solid ceramic form presents the quintessential mountainside aesthetic. An aesthetic accentuated by the rocky, textured ceramic exterior available in bubblegum, terracotta or deep umbra; rising up to provide your bouquet the perfect lofted position.

neolit

by Studio Furthermore

This texture group – with an exterior mirroring the moon’s surface, and a near weightlessness to match – will transport you into a universe where everything is not as it seems. Heightening their connection to the stars is a process mirroring that of space missions from earth. Studio Furthermore has taken inspiration from NASA’s own use of ceramic foams to create pieces with depths and character. Each foam structure is then dipped in ceramic before being fired at a precise temperature. Much like a comet entering the atmosphere, a little piece of space magic is left behind.



potpourri

by Meike Harde

Pick them, pour them, roll them, and hold them; a kaleidoscope of colour, form and texture awaits. The Potpourri collections by Meike Harde transport her eye for colour and configuration into a playful collection of carafes and glasses. Bold and extremely playful; four mixed bag families brought together by a shared display of bright hues and obscure silhouettes.



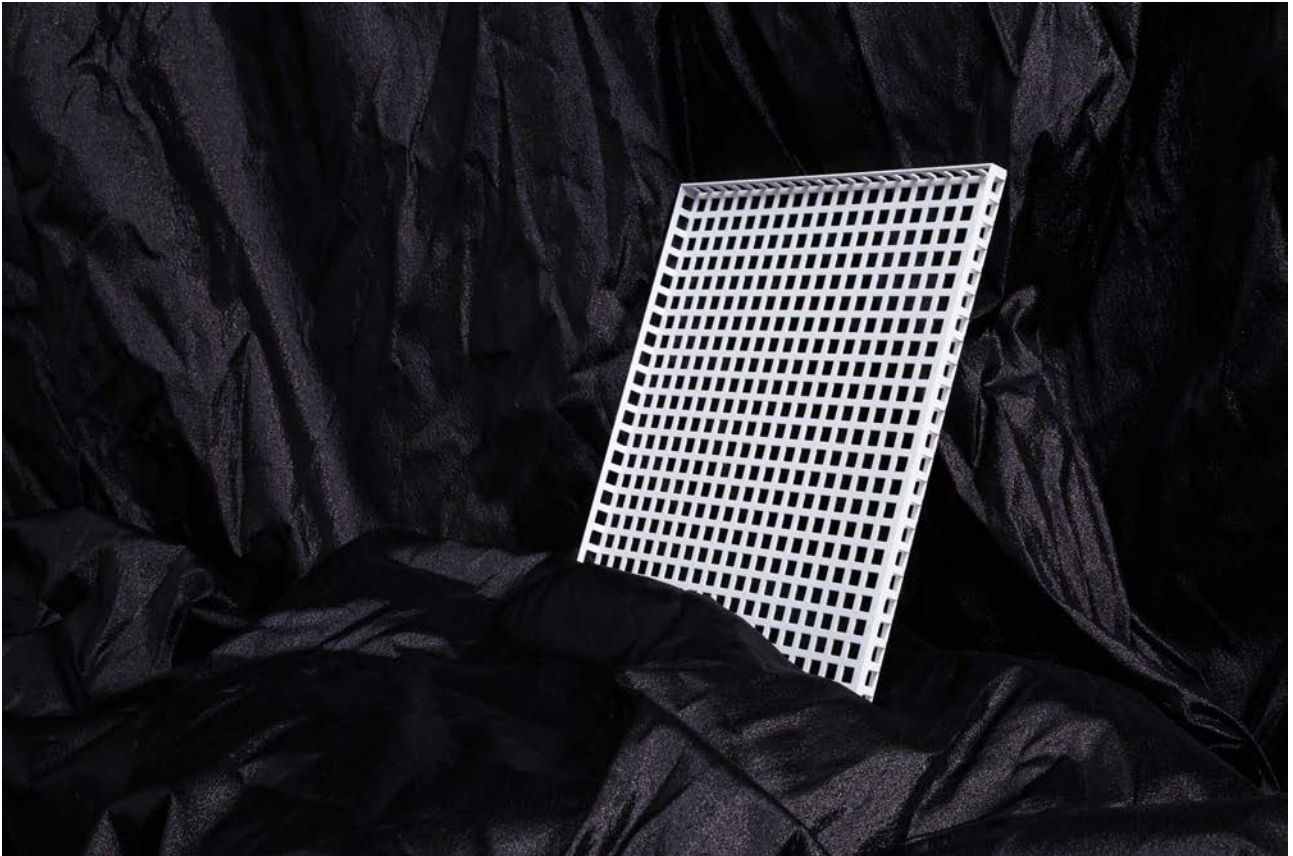

tray

by Peter Raacke

A stamped steel pattern allows Tray to have a light expression and a total commitment to functionality. Continuing Peter Raacke's award winning commitment to accessible design, a gridded steel form is turned up slightly on each side to present a simple surface in which to hold and carry life's objects.

atoll

by Sebastian Herkner
CANDLE HOLDERS



ART. NR			COLOUR
SMALL	MEDIUM	BIG	
I600A	I601A	I602A	amber
I600AM	I601AM	I602AM	amethyst
I600B	I601B	I602B	blue
I600G	I601G	I602G	smoky grey
I600T	I601T	I602T	transparent

MATERIAL

glass

PROCESS

Each piece is handmade in Italy, created from transparent or coloured cast glass. Bubbles, streaks and other variations in size and colour are part of the production process, and not defects of the design or production.

DIMENSIONS mm

SMALL

80L x 75W x 40H

LARGE

300L x 140W x 40H

HIGH

320L x 220W x 40H

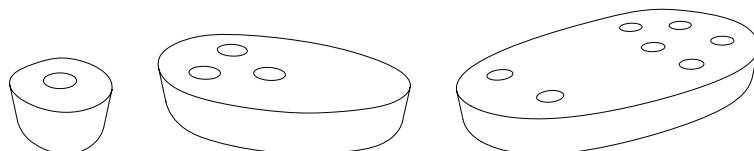

black

by pulpo
BOOK



ART. NR

COLOUR

8000B

black

MATERIAL

paper and fabric

PROCESS

Each piece is offset printed, and binded. The cover is made out of embossed black linen, then finished with black on the edges of the pages.

DIMENSIONS mm

340L x 245W x 20H

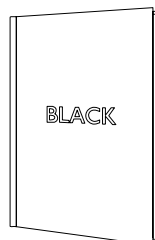

bola
by RSW
SET OF BOXES



ART. NR

5100

COLOUR

HANDLE	BOX
rose	black

MATERIAL

ceramic and wood

PROCESS

Each piece is made from beech wood, finger joined and stained. Each top piece is handmade in ceramic and applied with a glossy glaze. Streaks and other variations in size and colour are part of handmade production processes, and not defects in the design or production.

DIMENSIONS mm

SMALL

125L x 125W x 100H

BIG

220L x 220W x 80H

LONG

330L x 125W x 80H

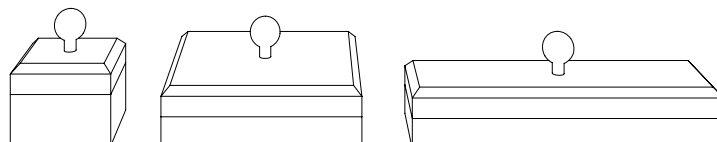

building

by Ferréol Babin
BOXES



ART. NR

SMALL

BIG

5404BL

5405BL

5404ME

5405ME

5404BR

5405BR

COLOUR

black

merlot

metal brown

MATERIAL

ceramic

PROCESS

Each piece is handmade from ceramic, and applied with a glossy glaze. Streaks and other variations in size and colour are part of handmade production processes, and not defects in the design or production.

DIMENSIONS mm

SMALL

145L x 115W x 235H

BIG

325L x 170W x 130H

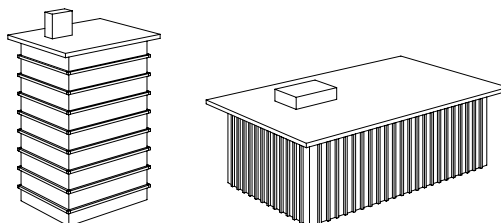

container

by Sebastian Herkner
 VASES / BOXES



ART. NR

LOW	HIGH
3010S	3020S
3010CO	3020CO
3010FU	3020FU
3010LA	3020LA
3010BL	3020BL
3010O-S	3020O-S
3010O	3020O
3010RO	3020RO
3010SI	3020SI
3010SR	3020SR

COLOUR

VASE	COVER
black	celadon green
cobalt	apricot
fuchsia	apricot
lagoon	apricot
light blue	red
orange	black
orange	blue
rose	blue
silver	poppy red
spicy red	celadon green

MATERIAL

glass

PROCESS

Each piece is created from handblown glass, colours and/or silvered. Bubbles, streaks and other variations in size and colour art part of handmade production processes, and not defects in the design or production.

DIMENSIONS mm

LOW
 230Ø x 170H
 HIGH
 165Ø x 300H

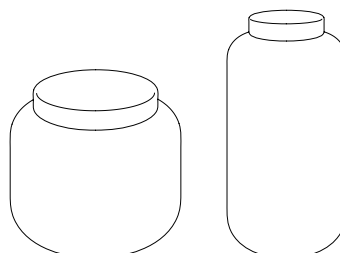

deer+giraffe+rhino+swan

by Kai Linke
STATUETTES



ART. NR

COLOUR

5700SET	bronze set of four animals
5700DE	bronze deer
5700GI	bronze giraffe
5700RH	bronze rhino
5700SW	bronze swan

MATERIAL

bronze

PROCESS

The statuette was crafted by hand using paper and tape. The final cast bronze form is then left untreated to reveal this design process. The natural patina of bronze will develop over time.

DIMENSIONS mm

DEER

140L x 70W x 180H

GIRAFFE

120L x 60W x 280H

RHINO

245L x 120W x 145H

SWAN

90L x 50W x 90H

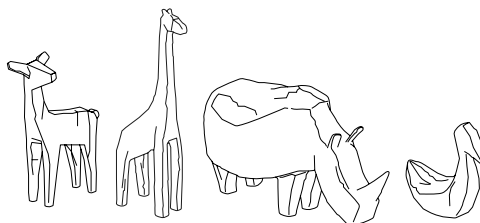

dita+olivia

by Davide Monopoli
MIRRORS



ART. NR

ART. NR		COLOUR	
DITA	OLIVIA	MIRROR	BASE
2100CO	2101CO	cobalt	black
2100FU	2101FU	fuchsia	black
2100BL	2101BL	light blue	black
2100Y	2101Y	lime yellow	black
2100RO	2101RO	rose	black
2100SI	2101SI	silver	black
2100SR	2101SR	spicy red	black

MATERIAL

glass and stone

PROCESS

Each piece is created from coloured and laminated glass mirror. The base is produced in natural black stone.

DIMENSIONS mm

DITA
300L x 140W x 280H

OLIVIA
150L x 130W x 380H

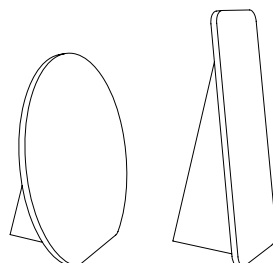

fg

by Visser & Meijwaard
VASES / BOX



ART. NR

1	2
I200B	I201B

COLOUR

COVER	VASE
black	black

MATERIAL

ceramic

PROCESS

Each piece is handmade from ceramic, and applied with a matt glaze. Streaks and other variations in size and colour are part of handmade production processes, and not defects in the design or production.

DIMENSIONS mm

- 1**
195Ø x 500H
- 2**
140Ø x 400H

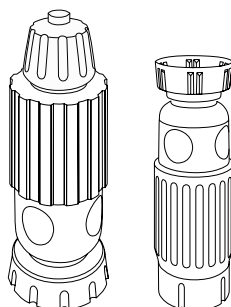

lake

by Ferréol Babin
TRAYS



ART. NR

SMALL

BIG

5402CO

5403CO

5402EM

5403EM

5402TU

5403TU

COLOUR

cobalt

emerald

tropical turquoise

MATERIAL

ceramic

PROCESS

Each piece is handmade from ceramic, and applied with a glossy glaze. Streaks and other variations in size and colour are part of handmade production processes, and not defects in the design or production.

DIMENSIONS mm

SMALL

270L x 200W x 40H

BIG

410L x 240W x 40H

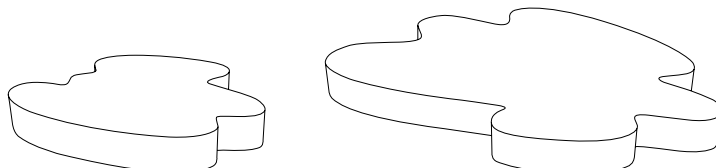

Ilano
by RSW
SET OF BOXES



ART. NR

5101

COLOUR

HANDLE	BOX
black	green

MATERIAL

ceramic and wood

PROCESS

Each piece is made from beech wood, finger joined and stained. Each top piece is handmade in ceramic and applied with a glossy glaze. Streaks and other variations in size and colour are part of handmade production processes, and not defects in the design or production.

DIMENSIONS mm

SMALL

120L x 120W x 90H

MEDIUM

140L x 140W x 110H

BIG

160L x 160W x 130H

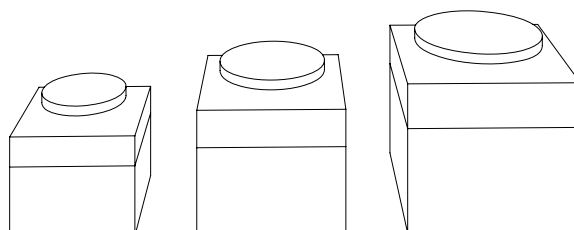

maket

by RSW
VASES / BOXES



ART. NR

SMALL	MEDIUM
5300CO	5301CO
5300GR	5301GR
5300PE	5301PE

COLOUR

TOP	BOTTOM
black	cobalt
black	graphite
black	peony

MATERIAL

ceramic

PROCESS

Each piece is handmade from ceramic, and applied with a fat lava glaze or a matt glaze. Bubbles, streaks and other variations in size and colour are part of handmade processes, and not defects in the design or production.

DIMENSIONS mm

SMALL
120Ø x 200H

MEDIUM
240Ø x 300H

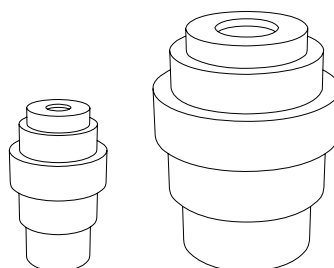

makeup

by Hermann August Weizenegger
VASES / BOXES

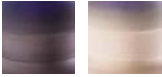

ART. NR

SMALL	MEDIUM	BIG
3700BI	3800BI	3900BI
3700VI	3800VI	3900VI

COLOUR

COVER	VASE - SMALL	VASE - MEDIUM AND BIG
iridescent brown	iridescent brown	brown
iridescent white	iridescent white	white

MATERIAL

ceramic

PROCESS

Each piece is handmade from ceramic, the cover is then applied with iridescent metallic pigments. Bubbles, streaks and other variations in size and colour are part of handmade processes, and not defects in the design or production.

DIMENSIONS mm

SMALL
225Ø × 250H

MEDIUM
225Ø × 300H

BIG
225Ø × 400H

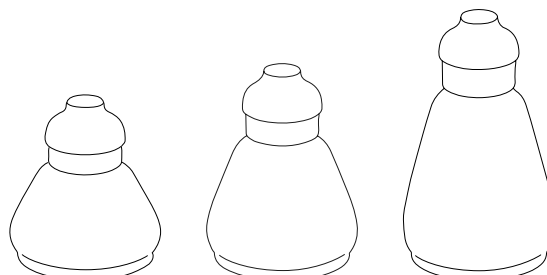

marelle

by Sacha Walckhoff
RUG

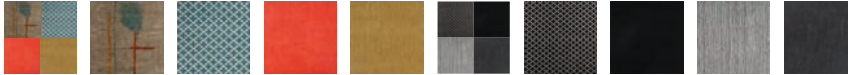

ART. NR

COLOUR

I800B-SET	black and white whole rug
I800B-01	black and white middle
I800B-02	black left
I800B-03	black and white top
I800B-04	grey right
I800C-SET	various whole rug
I800C-01	various middle
I800C-02	beige and blue left
I800C-03	vermillion top
I800C-04	yellow right

MATERIAL

wool and linen

PROCESS

Each section is produced from wool or linen, and can be connected by individual steel zips.

DIMENSIONS mm

WHOLE RUG

3250L x 3000W

MIDDLE

2500L x 1500W

TOP

1500L x 1000W

LEFT

1500L x 750W

RIGHT

1500L x 500W

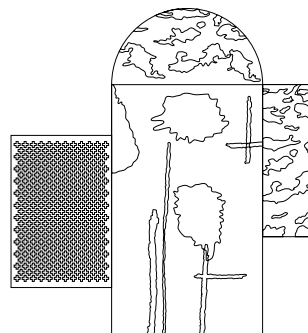

merit

by RSW
BOXES



ART. NR

SMALL

MEDIUM

5200CO

5201CO

5200GR

5201GR

5200PE

5201PE

COLOUR

TOP

BOTTOM

black

cobalt

black

graphite

black

peony

MATERIAL

ceramic

PROCESS

Each piece is handmade from ceramic, and applied with a fat lava glaze or a matt glaze. Bubbles, streaks and other variations in size and colour are part of handmade processes, and not defects in the design or production.

DIMENSIONS mm

SMALL

175Ø x 130H

MEDIUM

275Ø x 90H

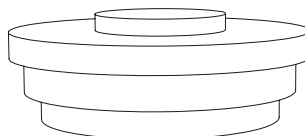
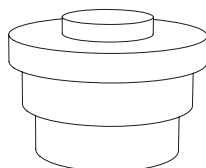

mila bowl

by Sebastian Herkner
BOWLS



ART. NR

SMALL

LARGE

2803S

2804S

2803BL

2804BL

2803GR

2804GR

2803RO

2804RO

2803VW

2804VW

2803Y

2804Y

COLOUR

black

blue

grey

rose

white

yellow

MATERIAL

ceramic

PROCESS

Each piece is handmade from ceramic, and applied with a glossy glaze. Streaks and other variations in size and colour are part of handmade production processes, and not defects in the design or production.

DIMENSIONS mm

SMALL

200Ø x 120H

LARGE

280Ø x 160H

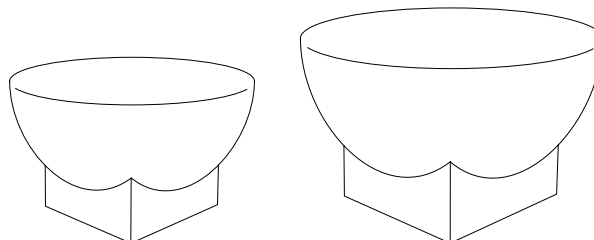

miro on the wall

by Meike Harde
MIRROR

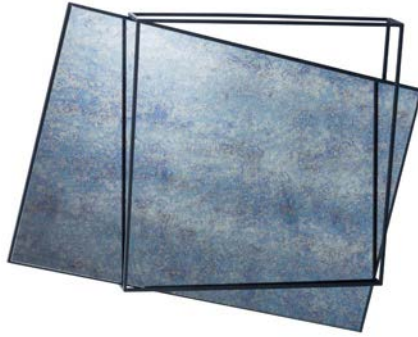

ART. NR

6400AN
6400SI

COLOUR

MIRROR	FRAME
antique	black
silver	black

MATERIAL

glass and steel

PROCESS

Each piece is created from glass sheet in a antique effect or a natural finishing, attached to a black MDF. The frame is constructed in black powder coated steel.

DIMENSIONS mm

FRAME
470L x 70W x 470H

MIRROR
650L x 10W x 450H

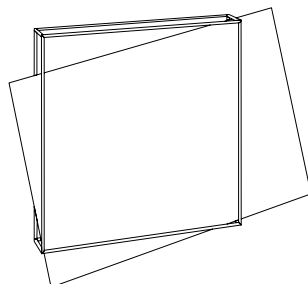

mountain

by Ferréol Babin
VASES



ART. NR

SMALL

BIG

5400BG

5401BG

5400TER

5401TER

5400UM

5401UM

COLOUR

bubblegum

terracotta

umbra

MATERIAL

ceramic

PROCESS

Each piece is handmade from ceramic, and applied with a textured glaze. Streaks and other variations in size and colour are part of handmade production processes, and not defects in the design or production.

DIMENSIONS mm

SMALL

210L x 90W x 220H

BIG

250L x 200W x 310H

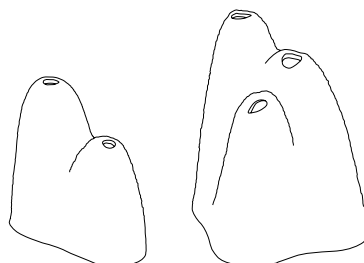

neolit

by Studio Furthermore
BOWLS

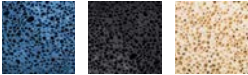

ART. NR

SMALL

BIG

LONG

COLOUR

6000CO

6100CO

6200CO

cobalt

6000GR

6100GR

6200GR

graphite

6000IV

6100IV

6200IV

ivory

MATERIAL

ceramic-covered foam

PROCESS

Each piece is handmade in foam before being immersed in ceramic and baked. Streaks and other variations in size and colour are part of handmade production processes, and not defects in the design or production.

DIMENSIONS mm

SMALL

335Ø × 90H

BIG

420Ø × 90H

LONG

530L × 290W × 150H

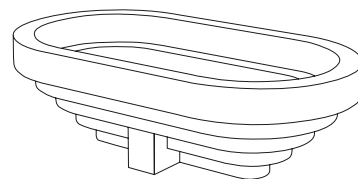
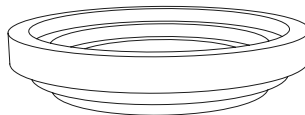

potpourri

by Meike Harde
CARAFES AND GLASSES



ART. NR

COLOUR

6600CAR	carafe 01 pink
6700CAR	carafe 02 cobalt
6800CAR	carafe 03 burgundy and opal white
6900CAR	carafe 04 dark amber and transparent
6600GL1	glass 01 milky white glass x3
6600GL2	glass 02 cobalt glass x3
6600GL3	glass 03 transparent glass x3
6700GL1	glass 04 pink and smoke green glass x3
6700GL2	glass 05 dark amber glass x3
6700GL3	glass 06 opal white glass x3
6800GL2	glass 07 transparent glass x3
6800GL3	glass 08 milky white glass x3
6900GL2	glass 09 smoke green glass x3
6900GL3	glass 10 burgundy glass x3

MATERIAL

glass

PROCESS

Each piece is created from handblown glass, coloured and and/or partly sanded. Bubbles, streaks and other variation in size and colour are part of handmade production process, and not defects in the design or production.

DIMENSIONS mm

CARAFE 01

85Ø × 300H

CARAFE 02

150Ø × 280H

CARAFE 03

170Ø × 190H

CARAFE 04

150Ø × 285H

GLASS 01

105Ø × 65H

GLASS 02

110Ø × 90H

GLASS 03

100Ø × 100H

GLASS 04

110Ø × 120H

GLASS 05

100Ø × 90H

GLASS 06

100Ø × 100H

GLASS 07

70Ø × 90H

GLASS 08

90Ø × 90H

GLASS 09

85Ø × 85H

GLASS 10

100Ø × 110H

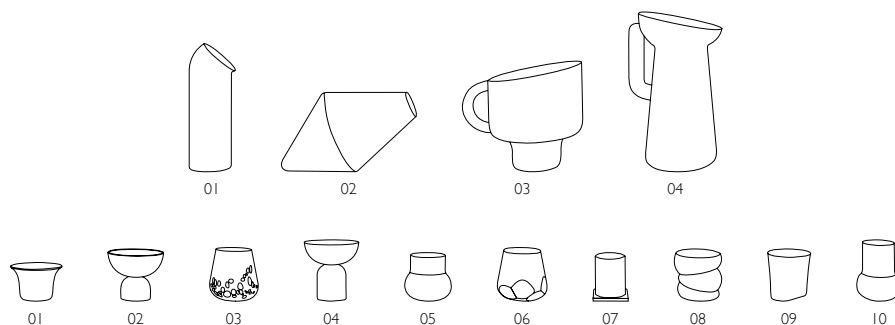

tray

by Peter Raacke
TRAY

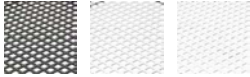

ART. NR

COLOUR

I027S

black

I027CHR

chrome

I027W

white

MATERIAL

steel

PROCESS

Each piece is constructed in either steel; powder coated or chrome plated.

DIMENSIONS mm

350L x 300W x 15H

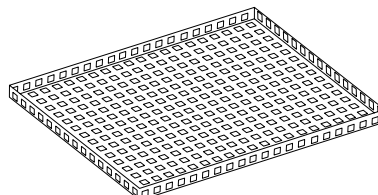

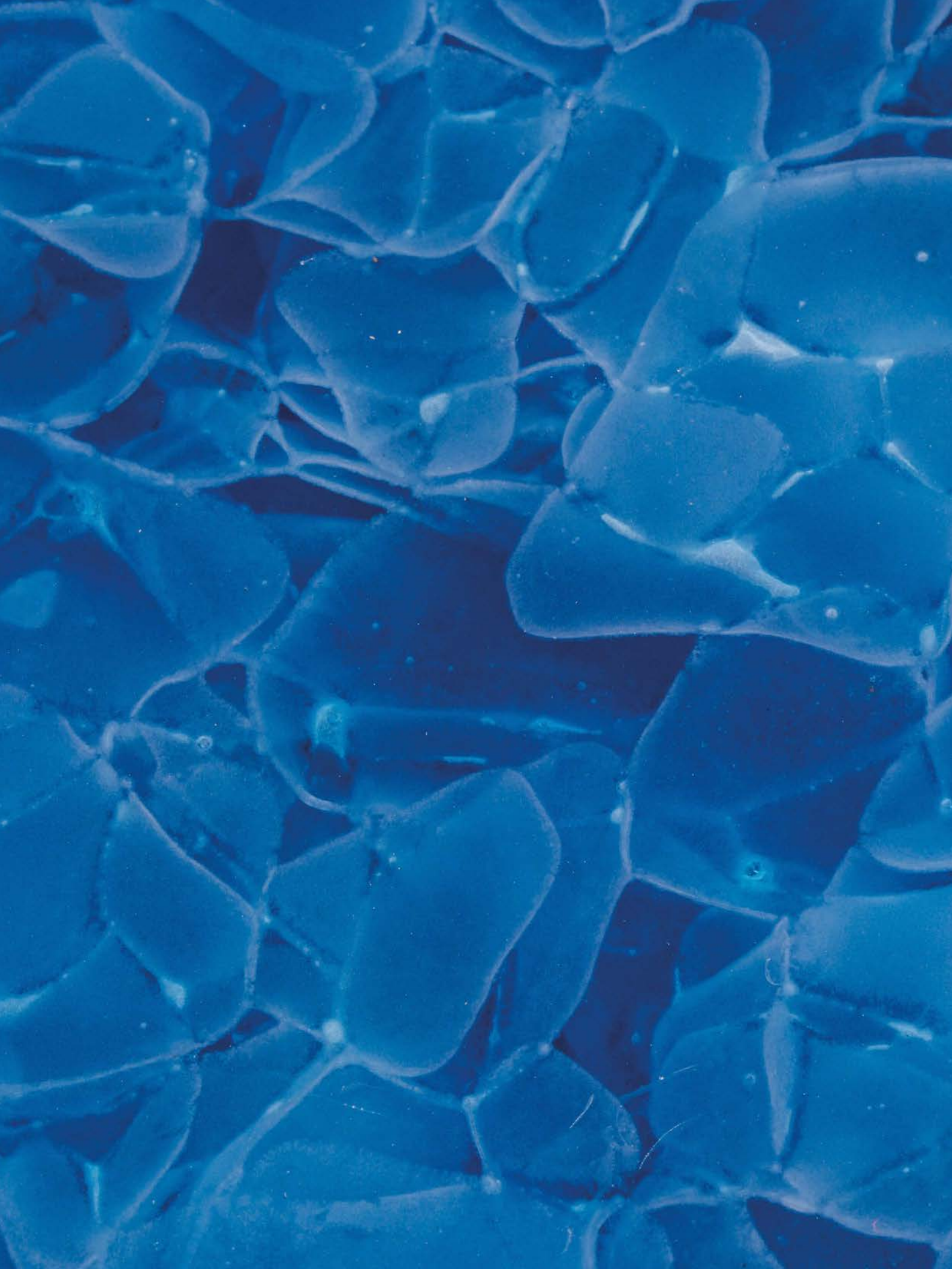



LETS KEEP IN TOUCH LETS KEEP IN TOUCH LETS

... ON SOCIAL

[instagram.com/pulpoproducts](https://www.instagram.com/pulpoproducts)

[facebook.com/pulpoproducts](https://www.facebook.com/pulpoproducts)

[pinterest.com/pulpoproducts](https://www.pinterest.com/pulpoproducts)

[linkedin.com/company/pulpo-gmbh](https://www.linkedin.com/company/pulpo-gmbh)

KEEP IN TOUCH **LETS KEEP IN TOUCH** LET

... IN PERSON

IMM, Cologne

14 - 20 January 2019

Maison&Objet, Paris

18 - 22 January 2019

Salone del Mobile, Milan

9 - 14 April 2019

EuroLuce, Milan

9 - 14 April 2019

Maison&Objet, Paris

6 - 10 September 2019

ACT CONTACT CONTACT CONTACT CONTACT C

phone

+49 7621 168 01 03

website

www.pulpoproducts.com

CONTACT CONTACT CONTACT **CONTACT** COI

main

info@pulpoproducts.com

dealer

dealer@pulpoproducts.com

contract business

cb@pulpoproducts.com

press

press@pulpoproducts.com

photography
pulpo GmbH
Thomas Wiuf Schwartz

pulpo GmbH

represented by the managing directors Patrick L'hoste and Ursula L'hoste

Herrenstrasse 4, 79539 Lörrach, Germany

info@pulpoproducts.com

+49 7621 168 01 03

www.pulpoproducts.com

#pulpoproduct

[instagram.com/pulpoproducts](https://www.instagram.com/pulpoproducts)

[facebook.com/pulpoproducts](https://www.facebook.com/pulpoproducts)

[pinterest.com/pulpoproducts](https://www.pinterest.com/pulpoproducts)

[linkedin.com/company/pulpo-gmbh](https://www.linkedin.com/company/pulpo-gmbh)

© pulpo GmbH 2019

All intellectual property, such as trademarks, copyrights and patents are reserved. Nothing contained in this brochure may be reproduced without written permission.

pulpo GmbH accepts no responsibility for typographical errors, and reserves the right to make any changes necessary without prior notice.

www.pulpoproducts.com