

# DATASHEET

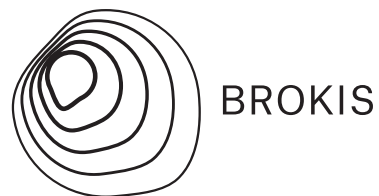

**Name** Floor lamp

**Type** Muffins 03A

**ID** PC852

**Description** The timeless Muffins collection represents an extraordinary lighting experience. Since its market debut, it has taken on an iconic status and become a symbol of the Brokis brand. The sublimity of the design lies in the masterful combination of delicately contoured glass and solid wood.

**Tech. description** The lamp consists of a solid wooden base, which houses the bulb socket, and a glass shade.



## CONSTRUCTION SPECIFICATION

<b>Weight [kg]</b>	7 kg
<b>Construction material</b>	glass, wood, metal
<b>Cord length [mm]</b>	2,330 mm
<b>Mounting</b>	Floor
<b>Environment</b>	Indoor

## ELECTRICAL SPECIFICATION

<b>Input voltage [V]</b>	230 VDC
<b>Frequency [Hz]</b>	50-60 Hz
<b>Max. power [W]</b>	60 W
<b>Coverage IP</b>	20
<b>Socket</b>	E27
<b>Light source</b>	-
<b>Energy class</b>	A+ to E depending on light source

## Dimensions [mm]

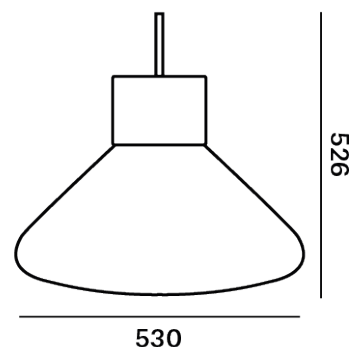

## Certifications



# DATASHEET

## RECOMMENDED BULBS

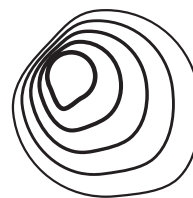

BROKIS



### SEGULA 50296

<b>Socket</b>	E27
<b>Type</b>	LED filament
<b>Lamp wattage [W]</b>	6 W
<b>Input voltage [V]</b>	220 - 240 VAC
<b>Energy class</b>	A+
<b>Flux[lm]</b>	470 lm
<b>Light Colour [K]</b>	2,200 K
<b>CRI</b>	90+
<b>Lifespan [h]</b>	20,000h
<b>Dimmable</b>	yes
<b>Dimensions h x w [mm]</b>	142 x 62 mm

# TECHNICKÝ LIST



**Název** Podlahové svítidlo

**Typ** Muffins 03A

**ID** PC852

**Popis** Nadčasová svítidla Muffins přinášejí mimořádný zážitek z osvětlení. Od doby uvedení na trh se stala téměř ikonickými mezi svítidly a symbolem značky Brokis. Jejich jedinečnost tkví ve spojení jemných křivek skla a masivního dřeva.

**Technický popis** Svítidlo je složeno z masivní dřevěné podstavy, ve které je umístěna montura s objímkou žárovky, a skleněného dílu, který slouží jako stínítko.



## KONSTRUKČNÍ SPECIFIKACE

<b>Hmotnost [kg]</b>	7 kg
<b>Použité materiály</b>	sklo, dřevo, kov
<b>délka připojovacího vodiče [mm]</b>	2330 mm
<b>Montáž</b>	Podlaha
<b>Prostředí</b>	Vnitřní

## ELEKTRICKÁ SPECIFIKACE

<b>Jmenovité napětí [V]</b>	230 VDC
<b>Frekvence [Hz]</b>	50 - 60 Hz
<b>Max. příkon [W]</b>	60 W
<b>Krytí IP</b>	20
<b>Patice</b>	E27
<b>Světelný zdroj</b>	-
<b>Energetická třída</b>	A+ až E dle použitého zdroje

## Rozměr [mm]

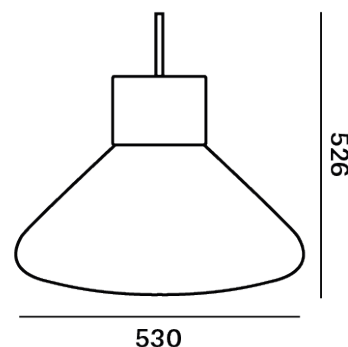

## Certifikace



# TECHNICKÝ LIST

## DOPORUČENÉ SVĚTELNÉ ZDROJE

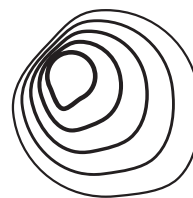

BROKIS



### SEGULA 50296

<b>Patice</b>	E27
<b>Typ</b>	LED filament
<b>Příkon [W]</b>	6 W
<b>Vstupní napětí [V]</b>	220 - 240 VAC
<b>Energetická třída</b>	A+
<b>Světelný tok [lm]</b>	470 lm
<b>Barevná teplota [K]</b>	2200 K
<b>CRI</b>	90+
<b>Životnost [h]</b>	20000h
<b>Stmívatelnost</b>	ano
<b>Rozměry v x š [mm]</b>	142 x 62 mm